



Automated External Defibrillator (AED) Program

Initiator: Tracy Stark

Revised by: Julian Corral/ Karla Hill/ Anthony Yanez

Revision Date: August 29, 2024

Table of Contents

1. AED Program Description	5
2. Scope	5
3. Definitions	6
4. Responsibilities	7
5. Program Components	11
5.1 Process of Obtaining an AED	11
6. AED Unit Inspection	14
7. Repair Process	15
8. Reporting Requirements	18
9. AED Response Protocol	19
9.1 Initial Protocol for Unresponsive Victim	19
9.2 Begin AED Response	19
9.3 When EMS Arrives	20
9.4 Post-Use Procedure	20
10. Laws / Legislation Reference Date Summary	22
11. Frequently Asked Questions (FAQs) about Automated External Defibrillators	23
12. References	25
Appendix A: AED Unit and Renewal Cost	26
A.1 Initial and Renewal Cost of Adults Only AED Unit	26
A.2 Adults Only AED Unit Campus Installation Cost	27
A.3 Adults Only AED Unit Total Cost with Installation	27
A.4 Annual Agreement Cost per Adults Only AED Unit (Year 2-10)	27
A.5 Product Usage, Replacement and Expiration Costs for Adult AED Unit	28

A.6 Initial Cost of Adults and Pediatrics Unit.....	28
A.7 Adults and Pediatrics AED Unit Campus Installation Cost.....	30
A.8 Adults and Pediatrics AED Unit Total Cost with Installation.....	30
A.9 Annual Agreement Cost per Adults and Pediatrics AED Unit.....	31
A.10 Product Usage, Replacement and Expiration Costs for Adult and Pediatrics AED Unit.....	31
Appendix B: Planning, Design & Construction (PD&C).....	33
B.1 New Construction and Alterations Requiring AEDs.....	33
B.2 Health and Fitness Centers.....	37
B.3 Location of AEDs.....	37
B.4 AED Installation and Repair.....	37
B.5 AED Cubix Cabinet Dimensions and Specifications.....	38
B.6 AED Placement Guidelines.....	43
B.7 AED Cabinet Installation.....	43
B.8 AED Cabinet Height.....	43
B.9 AED Cabinet Protrusion.....	44
B.10 2010 ADA Standards.....	44
B.11 Signage.....	47
Appendix C: Facilities Services - AED Placement Guidelines.....	48
C.1 AED Cabinet Installation.....	48
C.2 AED Cabinet Height.....	48
C.3 AED Cabinet Protrusion.....	49
C.4 2010 ADA Standards.....	49
C.5 AED Cubix Cabinet Dimensions and Specifications.....	52
C.6 Signage.....	57

Appendix D: Automated External Department (AED) Request Form58

Appendix E: UC Riverside AED Post Use Form59

1. AED Program Description

In order to enhance survival rates in instances of out-of-hospital Sudden Cardiac Arrest (SCA), the American Heart Association advocates for lay rescuer Automated External Defibrillator (AED) programs. At UC Riverside, emergency medical services fall under the jurisdiction of the Riverside County Emergency Medical Services Agency. All departments and entities procuring AEDs are obligated to adhere to the specified guidelines and requirements including registration with county Emergency Medical Services.

UCR remains steadfast in its dedication to the well-being of all members of the campus community, including visitors, while ensuring compliance with California legislative mandates. Pursuant to [California legislative code 104113](#), the presence of an AED program is mandated for all health studios and health clubs. Furthermore, Senate Bill No. 1397, effective January 1, 2017, necessitates the installation of AEDs in newly constructed high occupancy buildings.

[California Health and Safety Code §19300](#) dictates the inclusion of defibrillators in specific buildings renovated post January 1, 2017. AED installation is mandatory for high occupancy structures undergoing modifications, renovations, or tenant improvements amounting to \$100,000 or more within a single calendar year. This requirement encompasses commercial, educational, childcare facilities, institutional, retail, residential, and factory buildings with an occupancy load of 200 or more individuals.

Moreover, AEDs are obligatory in assembly buildings featuring auditoriums, lecture halls, and meeting spaces, such as taverns and bars, art galleries, community halls, dance halls, lecture halls, libraries, museums, greenhouses, pools, and tennis courts, with an occupancy exceeding 300 individuals. In assembly buildings, there is no monetary threshold for mandated improvements.

2. Scope

The UCR AED Program serves as a comprehensive framework for all departments and individuals at UCR who possess AED units on their premises, providing supervision and assistance to participating entities campus-wide. The aim of this document is to institute uniform guidelines for the application process, placement, upkeep, and other essential aspects outlined within the program. Designed to function as both a guide

and a checklist, this program ensures adherence to the necessary elements consistent with regulatory requirements.

3. Definitions

- **AED Department Designee:** Each location with an AED must designate an individual(s) who will be responsible for maintaining the AED and completing the monthly check.
- **AED Program Coordinator:** Environmental Health and Safety (EH&S) personnel responsible for providing guidance and assistance in all matters involving the AED campus program.
- **Automated external defibrillator (AED or defibrillator):** An automated computerized medical device programmed to analyze heart rhythm, recognize rhythms that require defibrillation, and provide visual and voice instructions for the device operator including, if indicated, to push the button to deliver an electric shock.
- **Building owners:** must ensure that tenants annually receive a brochure, approved as to content and style by the American Heart Association or American Red Cross, which describes the proper use of an AED, and also ensure that similar information is posted next to any installed AED.
- **Bystander first aid/CPR:** Initial first aid/CPR provided by a trained individual who is not part of an organized medical response system such as ERT or EMS.
- **Cardiac Arrest Assessment:** The time from collapse to an assessment of the medical situation can take at least one minute. The chances of a victim surviving a sudden cardiac arrest decrease seven to ten percent for each minute that passes without treatment.
- **Cardiopulmonary resuscitation (CPR):** Rescue breathing and external cardiac compression applied to a victim in respiratory and/or sudden cardiac arrest.
- **Chain of Survival:** A four-step process for treating victims of sudden cardiac arrest (SCA). When implemented early in a cardiac event, the chain of survival can improve chances of survival dramatically. Developed by The American Heart Association in 1990, the Chain of Survival has become the standard of care for cardiac victims. The four steps in the process are:
 1. Early Access – contacting 911
 2. Early CPR – administering CPR
 3. Early Defibrillation – apply an AED
 4. Early Advanced Care – Engaging professional responders.
- **Emergency Medical System (EMS):** refers to a professional agency comprised of community responders who are dispatched during emergencies to provide medical assistance and/or ambulance transport. In California, it is mandatory for all Automated External Defibrillators (AEDs) to be registered with the Local EMS Agency.
- **Good Samaritan Protection:** a Health and Safety Code § 1797.196 – 2006 Provides

Good Samaritan protection for use of an AED and establishes guidelines for AED programs.

- **Maintenance Program:** The AED must be maintained and regularly tested according to the operation and maintenance guidelines set forth by the manufacturer, the American Heart Association, and the American Red Cross, and according to any applicable rules and regulations set forth by the governmental authority under the federal Food and Drug Administration and any other applicable state and federal authority.

The AED must be checked for readiness after each use and at least once every 30 days if the AED has not been used in the preceding 30 days. Records of these checks shall be maintained. There must be a written plan that describes the procedures to be followed in the event of an emergency that may involve the use of an AED. The written plan shall include, but not be limited to, immediate notification of 911 and trained office personnel at the start of AED procedures. Building owners must ensure that tenants annually receive a brochure, approved as to content and style by the American Heart Association or American Red Cross, which describes the proper use of an AED, and also ensure that similar information is posted next to any installed AED. No less than once a year, building owners will notify their tenants as to the location of AED units in the building.

- **Medical Director:** Issues the prescription required by the FDA for AED purchases.
- **EMS Notification:** Any person or entity that supplies an AED shall notify an agent of the local EMS agency of the existence, location, and type of AED acquired.
- **Medical Emergency Response Team (MERT):** This is a group of medical responders who train on a regular basis to respond to medical emergencies.
- **Notification of Use:** Any person who renders emergency care or treatment on a person in sudden cardiac arrest by using an AED must activate the emergency medical services system as soon as possible and report any use of the AED to the licensed physician and to the local EMS agency.
- **Rescue breathing:** Artificial ventilation of a victim in respiratory and/or sudden cardiac arrest.
- **Sudden cardiac arrest (SCA):** A significant life-threatening event when a person's heart stops or fails to produce a pulse.

4. Responsibilities

AED Department Designee is responsible for:

- Maintaining AED equipment according to manufacturer specifications and campus AED program requirements
- When necessary, clean the defibrillator using recommended cleaning agents, per the defibrillator usage manual. The AED manuals are available via the [Occupational Health](#) website or visit [Philips FRX AED](#) manual, [Philips Onsite AED](#) manual, [ZOLL AED PLUS](#) manual.

- Document monthly equipment inspection through the campus AED online monitoring system.
- In the event of an AED emergency use, remove the AED to a secure location then notify EH&S AED Program Coordinator as soon as possible by either: emailing ehsocchealth@ucr.edu, calling 951-827-5528, or In-person within 24 hours of an incident. The AED must only be turned over to EH&S.
- Participated in case reviews, responder training and retraining, data collection and other quality assurance activities.
- Develop and maintain the emergency response plan and UCR policies and procedures.
- Maintain a list of trained early defibrillation responders.
- Ensure compliance with UCR policies and procedures of the Early Defibrillation Program
- Is the primary recharge contact for department oversight.

Campus Chancellor is responsible for:

- Ensuring compliance with health and safety requirements across all facilities and programs under their jurisdiction.

CPR1 - AED Total Solutions (contractor) responsible for:

- Provide Prescription/medical oversight.
- Notify Riverside County of AED installation and registration.
- Supply replacement pads and parts as needed.
- Provide online AED portal.
- Download event data, have physician review, prepare any necessary notifications, and supply post-event report.
- Online management program with reminders, notifications, tracking, & reporting
- Interactive reporting console
- Protocol and EMS templates.
- Post event review with loaner AED.
- Online resource library
- Data entry/batch upload
- EMS registration
- Tracking System
- All of the AED units on campus are connected to this system and EH&S will recharge departments for the annual required license.

Department Heads are responsible for:

- **Designating a Department AED Coordinator:** Assigning a coordinator to oversee AED-related activities within the department and coordinate with EH&S.
- **Purchasing, Installing, and Maintaining AEDs:** Ensuring AEDs are acquired, properly installed, and regularly maintained in compliance with departmental requirements that exceed building requirements for AEDs, as mandated by outside entities requiring it from the campus.
- **Coordinating Training for Employees:** Organizing and facilitating AED training sessions for departmental staff, including the required First Aid training for employees that are outside the campus building requirements.
- **Maintaining Records of Maintenance and Testing:** Keeping detailed records of AED maintenance and testing activities, and using the campus system to record and report any issues.
- **Retaining AED Training and Maintenance Records:** Storing all AED training records and equipment maintenance/testing logs, which must be available for review by EH&S or Fire building inspections.

Employees are responsible for:

- Understanding their roles and responsibilities within their department's Emergency Action Plan. This includes knowledge of building evacuation routes, proper use of fire extinguishers and alarms, accessing emergency services, and responding appropriately during emergencies.

Environmental Health & Safety (EH&S) AED Program Coordinator is responsible for:

- Assisting in all inquiries regarding AEDs
- Ensure all AED purchases and replacement items through campus procurement go through the appropriate vendor, and recharges annual fees as necessary.
- Assists in placing the acquired AED in an unlocked accessible location and departments need to ensure that AED coordinator has access to get the AED in the event of an emergency.
- Conducting annual inspections of AED equipment for quality assurance through the online system as required.
- Communicating with department designee(s) on all AED matters
- Document monthly equipment inspections through the campus AED online monitoring system for public areas and recharges for locations without an AED Department Designee.

- In the event of AED emergency use, will assist in obtaining event information and filing of the AED event notification.
- Coordinates AED Total Solutions program subscription service and access for UCR employees.
- Communicate to site management the costs and benefits of expanding the existing medical emergency response by including defibrillator use.
- Review the program annually to evaluate effectiveness.

Facilities Services is responsible for:

- Ensuring that buildings are remodeled in compliance with appropriate codes applicable to UCR and according to the policies and procedures for the projects they manage.
- This includes ensuring that AED Placement Guidelines are followed, including cabinet installation.
- The EH&S Department shall be involved in the project during the earliest stages to reduce the potential for unnecessary expenses. Facilities Services will provide plans and specifications to EH&S for review of AED or Stop the Bleed installation conformance to the referenced codes and standards.
- Additionally, recently retrofitted buildings must incorporate defibrillators in accordance with California Health and Safety Code §19300. This mandate applies to structures renovated after January 1, 2017, particularly those undergoing modifications, renovations, or tenant improvements exceeding \$100,000 within a calendar year.

Fire and Life Safety Program is responsible for:

Integrating the AED program as a vital component of the campus's overall emergency preparedness and response strategy. Their responsibilities include:

- **Coordinating with EH&S:** Working closely with the Environmental Health and Safety (EH&S) Department to ensure that AED placement and maintenance meet all applicable codes and standards. This includes providing plans and specifications to EH&S for review and approval. Providing comprehensive training for the campus community on fire safety and AED usage. This includes regular fire drills and AED training sessions to ensure that individuals are prepared to respond effectively to both fire and cardiac emergencies.
- **Raising Awareness and Education:** Educating the campus community about fire hazards, prevention practices, and the importance of AEDs in emergency situations. This includes distributing informational materials, conducting workshops, and promoting a culture of safety.

- **Compliance and Reporting:** Ensuring compliance with California Health and Safety Code §19300 regarding the incorporation of defibrillators in newer constructions and recently retrofitted buildings. Reporting on the status of AED implementation and any incidents involving AED use.

Planning, Design & Construction (PD&C) is responsible for:

- Ensuring that buildings are constructed and/or remodeled in compliance with appropriate codes applicable to UCR and according to these policies and procedures for the projects they manage.
- The EH&S Department shall be involved in the project at the earliest stages to reduce the potential for unnecessary expenses.
- PD&C will provide plans and specifications to EH&S for review of AED conformance to the referenced codes and standards.
- Additionally, newer constructions and recently retrofitted buildings must incorporate defibrillators in accordance with California Health and Safety Code §19300. This mandate applies to structures renovated after January 1, 2017, particularly those undergoing modifications, renovations, or tenant improvements exceeding \$100,000 within a calendar year.
- All new construction and renovations on UCR property must incorporate an AED within a dedicated cabinet, strategically placed in the first-floor lobby near the main elevator, stairs, or another prominent location approved by EH&S, as part of the project design.

Supervisors are responsible for:

- Training their employees on appropriate emergency response activities, including the locations of AEDs.

Vice Chancellors, Directors, Deans, and Department Chairs are responsible for:

- For communicating and promoting the AED program within their respective units and enforcing the policy within their areas of control.

5. Program Components

5.1 Process of Obtaining an AED

1. Uniformity and Approval:

- To ensure uniformity across the campus in our online systems and communication procedures with Emergency Medical Services (EMS) and the designated medical director, UCR requires that all its entities acquire only

AED devices approved by EH&S. For details on purchasing, please reach out to ehsocchealth@ucr.edu.

2. Cost Sharing and Compliance:

- Starting April 1, 2024, all University of California, Riverside (UCR) departments possessing Automated External Defibrillator (AED) units will share the associated costs. These AED units, which must be under medical prescription and oversight by the Food and Drug Administration (FDA), require a physician to ensure compliance with state laws and guidelines, including training, notification, and maintenance protocols. This approach supports our commitment as a higher education institution to maintain uniform medical supervision across all AED units.

3. Cost Distribution:

- With the campus now hosting over 50 AED units, costs will be distributed according to the number of units each department manages or based on relevant legislation. Relevant legislation includes CA SB 1397 (2018), CA-AB 1766 (2018), CA Ed Code § 51225.6 (2016), CA Ed Code § 49417 (2015), and CA Health and Safety Code § 19300 (2015), which outline AED requirements for buildings, public swimming pools, and occupancy structures. The AED units purchased for these purposes will be covered under the campus budget and be part of the UCR AED program oversight. However, replacements of units that do not fall under these legislative requirements will be the responsibility of the individual departments or units. For example, AED units intended for building purposes must be publicly accessible and strategically placed. If the units do not serve this purpose but are still required, their procurement and maintenance will be the responsibility of the respective department or unit while still being part of the UCR AED program and medical oversight.

4. Installation Location:

- The selection of an AED's installation location within a building is a collaborative process. Specific guidelines are set forth in Appendix B and C as part of the building requirements. Because departments may not purchase their own AEDs independently, all units used under UCR need to maintain campus-wide medical oversight, including the use of standardized units. If a department wishes to purchase an AED unit for any requirement not covered by the California codes, those units will need to be purchased by the department or units to meet those requirements, and the department will be recharged annually for medical oversight, including the use, deployment, unit parts used to be replaced or if they are parts that are

expired. The EH&S AED Program Coordinator, or their delegate, partners with the department receiving the AED to pinpoint a location. This location is chosen for its public visibility and accessibility while also ensuring compliance with the Americans with Disabilities Act (ADA) and building code requirements.

5. New Construction and Retrofitting:

- Newer constructions and recently retrofitted buildings in accordance with California [Health and Safety Code §19300](#) must incorporate defibrillators. This mandate applies to structures renovated after January 1, 2017, particularly those undergoing modifications, renovations, or tenant improvements exceeding \$100,000 within a calendar year. The directive encompasses various building types, including commercial, educational, childcare facilities, institutional, retail, residential, and factory buildings with an occupancy load of 200 or more individuals. It is imperative that these newer constructions and building enhancements integrate defibrillators during the design phase. Additionally, all new construction and renovations on UCR property must incorporate an AED within a dedicated cabinet, strategically placed in the first-floor lobby near the main elevator, stairs, or another prominent location approved by EH&S, as part of the project design.

6. Identified Locations:

- Following the California Health and Safety Code, UCR has identified the locations that will need AED units if the structures, renovations, or tenant improvements exceed \$100,000 within a calendar year. You may review that list in Appendix C.

7. Department-Specific AEDs:

- If your department is interested in securing AED units for specific work areas or vehicles, separate from building installations, please contact ehsochealth@ucr.edu. Acquiring an AED is a significant investment, requiring a commitment of 8-10 years. The decision to deploy AEDs is based on a department's willingness and capacity to finance the program. Unfortunately, EH&S does not have campus central funds for AED deployment. Therefore, departments or units wishing to acquire an AED must arrange funding for both the initial setup and ongoing maintenance, which includes replacement batteries and pads, medical oversight, and integration with the online management system. The costs for all specific work areas and vehicle units requested will be the requesting department's responsibility.

8. Delivery and Responsibility:

- All AED units will be delivered to EH&S, including parts for the equipment. Each department will be responsible for providing a recharge account for the initial purchase of the unit and the annual charge. For more information, complete the [AED department request form](#).

9. Monthly Service Checks:

- Whenever feasible, it is recommended that a designated individual from the department or building occupants be assigned to perform monthly service checks through the online system and uphold equipment maintenance in accordance with [California Health and Safety Code 1797.196](#). In instances where a department or building does not have an assigned designee, annual recharge fees will be applied.

6. AED Unit Inspection

EH&S AED Program Coordinator or the Department Designee is responsible for completing monthly checks for AEDs unless an exception is made. The inspection includes verifying:

- Readiness indicator is positive – “green.”
- AED is not beeping or chirping.
- AED is in good condition.
- Supplies are available and unexpired.
- Two sealed unexpired pads
- Spare battery
- Child key: for locations where children may be present.
- Response kit

Once the monthly visual inspection is complete, the Department Designee must log onto the [AED Total Solutions monitoring website \(aedpm.com\)](#) and record the inspection completion and/or report any findings.

AED Readiness Check ×

- Check OK, AED Ready
- Readiness Indicator Negative
- AED is Chirping
- AED is Damaged
- Missing Supplies
- Expired Supplies
- Report Event/AED Use
- Other

Notes

optional notes

Cancel

Submit Check

Annual Inspection:

In addition to monthly checks, the EH&S AED Program Coordinator performs an annual onsite review of all AED units to ensure quality and reliability.

Reporting Issues:

Shall any problems or concerns arise during inspections or at any other time, it is crucial to promptly inform the EH&S AED Program Coordinator. This can be done via email at ehsocchealth@ucr.edu, by calling 951-827-5528, or in person within 24 hours of identifying an issue, ensuring swift action and maintenance of AED readiness.

7. Repair Process

In the event that the unit is not operable, the following steps shall be taken to address the issue to begin the repair process. This will only focus on the following options below: Readiness Indicator Negative, AED is Chirping and AED is Damaged option is selected.

- Please log in to your CPR1 portal to update your AED unit readiness check; this step is critical in troubleshooting your issue.

AED Readiness Check ×

Check OK, AED Ready

Readiness Indicator Negative

AED is Chirping

AED is Damaged

Missing Supplies

Expired Supplies

Report Event/AED Use

Other

Notes

optional notes

Cancel Submit Check

1. If the Readiness Indicator Negative option is selected, it indicates a potential issue with the AED. The readiness indicator, typically located at the top-right corner of the AED, undergoes daily, weekly, and monthly internal self-tests to ensure readiness for emergency use. These tests include internal shocks, circuitry checks, battery life assessments, and conductivity checks of the gel on the pads.
2. A green flashing light, green checkmark, or OK symbol confirms that the AED has passed all tests and is ready for use. Conversely, a negative indicator is denoted by a red flashing light, a red X, or another symbol, along with an intermittent chirping sound, signifying trouble. If the AED fails any internal test, the readiness indicator will switch to a red light, a red X, or other trouble symbol, often accompanied by an intermittent chirping sound.
3. Some AED models feature information buttons, allowing users to gather more details about the problem.

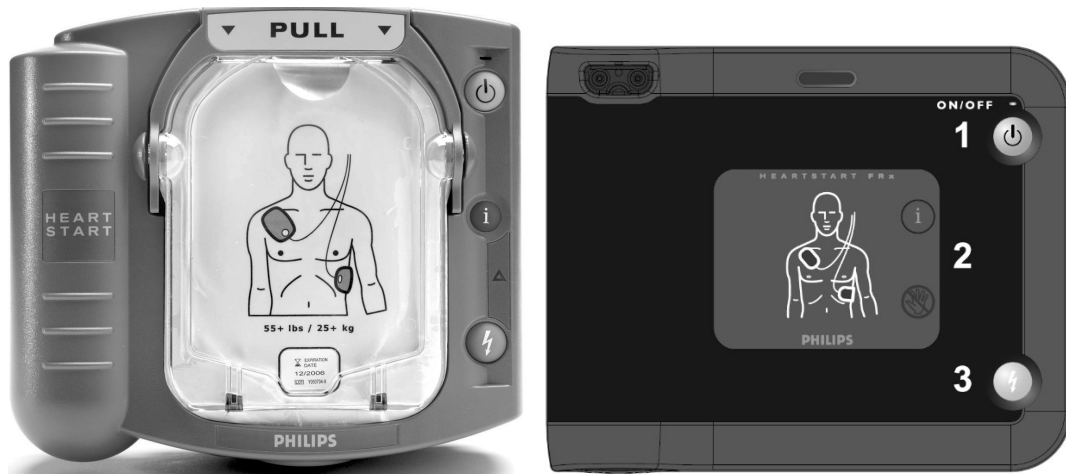

- If the AED displays a negative readiness indicator for any reason, please contact the EH&S AED Program Coordinator. You can reach out via email at ehsochealth@ucr.edu or by calling 951-827-5528. Alternatively, you can contact AED Total Solution at (855) 888-2771 or clientsupport@CPR1.com. They will collaborate with you to diagnose and resolve the issue.

- If the AED is Chirping option is selected, please follow the steps below based on your model. **One important point to remember is not to remove the battery** to stop the chirping. Removing the battery can potentially erase event data from the device. Contact the EH&S AED Program Coordinator to begin the repair process with CPR1.

- **If your model is the Philips FRx:**
 - The FRx's green Ready light is your guide to knowing if the defibrillator is ready for use.
 - If the Ready light is blinking: The FRx has passed the battery insertion self-test and the last periodic self-test and is therefore ready for use.
 - If the Ready light is solid: The FRx is in use or running a self-test.
 - If the Ready light is off, the FRx emits a series of single chirps, and the i-button flashes: A self-test error has occurred, the pads are faulty, the Infant/Child Key has been left installed, or the battery power is low. Press the i-button for instructions.
 - If the Ready light is off and the FRx emits a series of triple chirps, please call Philips for technical support.
 - If the Ready light is off but the FRx is not chirping and the i-button is not flashing, there is no battery inserted, the battery is depleted, or the defibrillator needs repair.

- Insert/replace the battery and run the self-test. As long as the FRx passes the self-test, it is ready for use.

- ☐ **If your model is the Philips Onsite:**
 - The Onsite Heartstart model green ready light is your guide to knowing if the defibrillator is ready for use.
 - If the Ready light is blinking: The HeartStart has passed the battery insertion self-test and the last periodic self-test and is therefore ready for use.
 - If the Ready light is solid: The HeartStart is in use or running a self-test.
 - If the Ready light is off, the HeartStart is emitting a series of single chirps, and the i-button is flashing: A self-test error has occurred, there is a problem with the pads or the battery power is low. Press the i-button for instructions.
 - If the Ready light is off, and the HeartStart is emitting a series of triple chirps, please call Philips for technical support. See “Troubleshooting a chirping HeartStart” on page 5-3 for more information.
 - If the Ready light is off but the HeartStart is not chirping and the i-button is not flashing, the battery is not inserted, the battery is depleted, or the defibrillator needs repair. Insert/replace the battery and run the self-test. As long as the HeartStart passes the self-test, you can be assured it is ready for use.

WARNING: Removing and reinserting the battery one or more times when an AED emits a series of triple chirps may reset the device and cause it to report it is ready for use, though it may be unable to deliver therapy during a rescue. Removing and reinserting the battery when your AED is emitting a pattern of triple chirps shall only be done during an emergency. **If your device is emitting a series of triple chirps in standby mode or after an emergency, please remove the AED from service and contact Philips immediately.**

If the unit cannot be fixed, the AED device (Philips) has an 8-year warranty. Replacement during the warranty period will be handled by Philips. If the unit is out of the warranty period, a new unit will need to be purchased.

For any further questions, please contact the EH&S AED Program Coordinator. You can reach out via email at ehsochealth@ucr.edu or by calling 951-827-5528.

8. Reporting Requirements

In the event of an AED emergency use, notify EH&S as soon as possible by either:

- ☐ Report online: [Report an Incident or Safety Concern](#)
- ☐ Email ehsochealth@ucr.edu

- Phone call (951) 827-5528
 - In-person within 24 hours of an incident at the Linden Street EH&S Office
- The EH&S AED Program Coordinator will collect all the event information and contact the AED program medical director. The medical director will review response data (e.g., ECG rhythm, responder and AED actions, unit performance), and submit a written report to Riverside County Public Health.

Following each use:

- The AED needs to be cleaned.
- All used or opened supplies shall be thrown away.
- Check supplies, accessories and spares for expiration date and damage.
- Check operation by removing and reinstalling the battery as well as running a battery insert test.

9. AED Response Protocol

The following protocol is for use by the Emergency Response or AED Team. CPR1 and our physicians issue the following to contracted clients for use by those who have been trained by a nationally recognized training provider (e.g., AHA, ARC, Medic First Aid, EMS (Emergency Medical System) only. The protocol will be replaced by a revised protocol, as necessary.

9.1 Initial Protocol for Unresponsive Victim

- Assess scene for safety; Use universal precautions.
- Assess victims for responsiveness.
- If unresponsive, activate EMS and in-house emergency plan by phoning 9-1-1 and/or designated number.
- Call for AED to be brought to the scene.
- Briefly assess patient's respiratory status (5-10 seconds)
- If respiratory effort is absent, or patient is only gasping, begin CPR (cardiopulmonary resuscitation) starting with compressions, at a depth of 2-2.4 inches for adults, or 1/3 the depth of the chest for children and infants.
- Continue CPR until AED arrives, alternating between 30 compressions and 2 breaths, at a rate of 100-120 compressions per minute.
- For a witnessed arrest, or if desired, use compression only CPR, without performing breaths.

9.2 Begin AED Response

- As soon as AED is available, turn on AED and follow prompts.

- If needed: Remove victim from pool of water (AED may be used on snow or ice)
- Wipe chest if wet from water or sweat.
- Shave chest with disposable razor. (Discard razor in the regular trash)
- Apply AED pads. *(For victims <55lbs or <8 years of age, use pediatric pads or pediatric setting if available. *) *Users of pediatric pads or pediatric setting shall have Infant and Pediatric CPR training.*
- Make sure that AED pads are placed in proper location and make good contact with victim's chest. Do not place AED pads over nipples, medication patches, or implantable medical devices. *(Note - if victim has an implantable cardiac defibrillator (ICD) which is discharging as evidenced muscle contraction similar to when an AED discharges, wait 30-60 seconds for cycle to complete before attaching AED pads.) (One inch/2.5 cm separation between AED pad placement and implantable medical device is recommended.)*
- If shock is recommended, shout "clear" and do not touch the victim. Deliver shock as advised by AED. Resume CPR for 2 minutes, then allow AED to assess the victim's rhythm. Repeat cycle as needed.
- Continue CPR and follow AED defibrillation prompts until otherwise directed by AED or EMS.
- Transfer responsibility for victim to EMS when directed or appropriate.

9.3 When EMS Arrives

- Responders shall document and communicate important victim information if known to EMS such as name, known medical problems, allergies, medical history, time found, initial and current condition, and information from the AED if available, number of shocks delivered, time of first shock.
- Assist as requested by EMS.

9.4 Post-Use Procedure

- Document AED use by completing the [UCR AED Post Use Form](#) (Appendix E) and contact UCR EH&S immediately at ehsocchealth@ucr.edu or by calling 951-827-5528.
- Secure the AED device and deliver to UCR EH&S immediately. The AED device must only be turned over to EH&S.
- The EH&S AED Program Coordinator will assist in obtaining event information and filing of the AED event notification.
- CPR1 will immediately provide a temporary unit and contact the UCR EH&S AED Program coordinator to arrange shipping for the used AED unit.

- CPR1 will download the event data and the assigned physician will review the data and file a report with EMS.
- CPR1 will clean, reset, replace the AED unit battery, and include new pads to ship back to the UCR campus.
- Once the AED unit has returned and been placed back into its original location, the loaner unit needs to be shipped back to CPR1.

10. Laws / Legislation Reference Date Summary

- **CA Civil Code § 1714.21**
2006 Grants Good Samaritan protection for UNTRAINED users.
- **CA Civil Code § 1714.2**
2006 Grants Good Samaritan protection for TRAINED users.
- **CA Health and Safety Code § 104113**
2007 Outlines AED requirements for health studios.
- **United States. 2010 ADA Standards for Accessible Design. Washington D.C.: Department of Justice**
2010 Outlines ADA Standards for accessible design requirements for newly designed and constructed or altered State and local government facilities, public accommodations, and commercial facilities to be readily accessible to and usable by individuals with disabilities.
- **16 CCR § 1070.8**
2011 Outlines AED requirements for dental offices.
- **CA Health and Safety Code § 19300**
2015 Outlines the occupancy structures that are required to have an AED on the premises.
- **CA Ed Code § 49417**
2015 Outlines fund receiving policies for schools with the intent on acquiring and maintaining an AED.
- **CA SB No. 658**
2015 establishes requirements for automated external defibrillators (AEDs) in public and private K–12 schools.
- **CA Ed Code § 51225.6**
2016 Outlines AED requirements for schools.
- **CA AB 1766**
2018 Requires public swimming pools to have an AED.
- **CA AB 2009**
2018 Requires CA schools to:
 - Ensure there is a written emergency action plan.
 - Acquire an AED for each school within a school district before July 1, 2019
 - Encourage that AEDs be available for emergency care.

- Ensure that an AED is available to athletic trainers and coaches.
- Ensure that AEDs are maintained and tested regularly.
- **CA SB 502**
2018 Outlines AED requirements for commuter rail systems.
- **CA SB 1397**
2018 Outlines AED requirements for buildings constructed on or after January 1, 2017
- **CA Health and Safety Code § 104113**
2019 Outlines requirements for health studios to ensure the availability and proper use of automatic external defibrillators (AEDs).
- **CA AB 1467**
2023 Requires AEDs at youth sports events; not everyone is allowed to use them, however.

11. Frequently Asked Questions (FAQs) about Automated External Defibrillators

What is an AED?

An AED, or Automated External Defibrillator, is a crucial device that delivers an electrical shock to a heart experiencing cardiac arrest, aiming to restore the heart's normal rhythm.

How does an AED work during cardiac arrest?

In cardiac arrest, the heart's electrical activity becomes irregular, halting effective blood circulation. An AED checks the heart's rhythm and determines if an electrical shock is necessary to reestablish a normal rhythm.

Are AEDs safe to use?

Yes, AEDs are safe and are programmed to administer a shock only, when necessary, with voice prompts guiding the user through the process.

When is it appropriate to use an AED?

An AED shall be used on individuals who are unconscious or suspected of having a cardiac arrest. The AED will assess the need for and deliver a shock if required.

What if an AED is mistakenly used on someone not in cardiac arrest?

The AED will not administer a shock if it's mistakenly used on someone who does not require one, ensuring safety in accidental applications.

How can I find AEDs on campus?

AEDs are located in accessible [areas across campus](#), available during business hours. For specific locations or to request an AED, contact the EH&S AED Program Coordinator at (951) 827-5528.

Do I need special training to use an AED?

While CPR knowledge is beneficial, anyone can operate an AED by following its voice-guided instructions, protected under California's Good Samaritan Law.

What shall be done immediately after an AED is used?

Replace the used electrode pads with a backup set to ensure the AED is ready for future emergencies. Do not remove the AED's battery as this may delete important data.

What steps follow reporting an AED event?

Upon reporting an AED event, a temporary replacement will be sent while your AED is reviewed for functionality. Your AED will be resupplied and returned ready for use at no cost, with used pads disposed of as standard trash.

How do I conduct my monthly AED Checks?

Perform a visual inspection to ensure the AED's readiness indicator is positive and supplies are up to date. Log onto AED Total Solution to record the check.

How do I record my monthly AED Checks?

Log onto AED Total Solution and select the AEDs checked. If your AED is ready, confirm the check. If issues are noted, record them for immediate notification and follow-up.

When shall monthly AED Checks be recorded?

Monthly checks shall be completed by the last day of each month, with reminders sent as the deadline approaches.

What is a readiness indicator?

A readiness indicator shows the AED's status through daily, weekly, and monthly self-tests. A green light or checkmark indicates readiness, while a red light or X suggests a problem.

What if my AED is chirping?

Do not remove the AED's battery. If the device chirps, indicating a problem, contact support immediately for assistance.

How will I receive new AED supplies?

The supplies shall be delivered to the EH&S office. The AED Program Coordinator will send an email notification to the Department AED Building designee upon delivery of the supplies.

Why are monthly AED Checks necessary?

Regular checks ensure your AED is ready for use, complying with laws for Public Access Defibrillators and protecting your organization from liability. All data is securely stored and accessible for compliance verification.

What to do with expired or used AED supplies?

Expired or used supplies can are non-toxic and can be disposed of in regular trash receptacles.

12. References

- California Emergency Medical Services Agency
 - [Information on Automated External Defibrillators](#)
- California Code of Regulations, Title 22
 - [Training Standards for the use of the Automated External Defibrillator by Non-Licensed or Non-Certified Personnel](#)
- California Health and Safety Code
 - [Health and Safety Code §19300 outlines AED requirements for buildings constructed on or after January 1, 2017](#)
 - [Section 1797.196 AED Program Requirements](#)
 - [Section 104113 Requirement for Automated External Defibrillators in Health Studios](#)
- California Civil Codes
 - [Section 1714.21 Liability in rendering emergency care](#)
- UCR Student Recreation Center CPR/AED Classes
 - [UCR Student Rec Activity Classes](#)
- UCR EH&S
 - [EH&S AED Program](#)
- 2010 ADA Standards for Accessible Design
 - [United States. \(2010\). 2010 ADA Standards for Accessible Design. Washington D.C: Department of Justice.](#)

Appendix A: AED Unit and Renewal Cost

The designated AED coordinator, along with the EH&S AED Program Coordinator, is responsible for overseeing the readiness and maintenance of AEDs across the campus, aligning with standards for pre-hospital care provided by lay responders. Furthermore, the EH&S AED Program Coordinator maintains a contract with a vendor to secure replacement parts and manage warranty claims as needed. By centralizing purchases through EH&S, we guarantee that the accessories are compatible with the specific models of AEDs deployed on campus, as well as with the equipment utilized by local first responders, ensuring seamless continuity of care.

A.1 Initial and Renewal Cost of Adults Only AED Unit

Adult Only AED Unit Cost Breakdown			
Product Number	Product Description	Unit Price* (Initial Cost)	**Renewal Cost (After 8-10 Years)
M5066A C01- Onsite	Philips Heart Start Onsite AED includes 4-Year Battery, 2-Year Adult Pads Cartridge, Standard Carrying Case, 8-Year Warranty.	\$1,153.60	\$1,153.60
FRK-RD	First Responder Kit - Red. Includes items typically needed in a cardiac arrest event. The nylon, zippered pouch contains (1) pair of nitrile gloves, a pocket CPR mask, scissors, razor, and (2) towelettes.	\$21.60	\$21.60
FR-S	Cubi fully recessed small defibrillator wall cabinet with window and alarm; inside tub measures 11 1/2" L x 11 1/8"H x 7"D; outside frame measures 13 1/2"L x 13"H x 1"D. Rough wall opening size: 12 1/2"L x 12 1/8"H x 6 1/4"D.	\$143.65	\$0.00
Flex3DWS-CPR1	Transforming wall sign that can be used in three different configurations (flat, corner, triangular). Each panel measures 6 1/8" W x 9" H. Total measurements at 14 7/8" W x 9" H.	\$19.00	\$0.00
AED Decal	AED Inside' Sticker: Premium Quality - Circular - White on Red Sticker. 5H x 5W.	\$2.95	\$0.00
Quick Poster AED-0	AED/CPR Quick Reference Poster, to be posted next to AED Dimensions: 16×10×16 in	\$4.95	\$4.95
Software, Adult Pads, and Batteries (Required Initial and Annual Expense)	Annual AED Total Solution (Adult w/ Spare Adult Pads) Includes: physician-provided medical oversight, written policies and procedures, an AED Total Solution Specialist, a customized AED Total Solution Web Portal and Mobile App, automatic no-cost replacement of pads and batteries, liability and safety consultation services, and post-event services.	\$231.00	\$231.00

Shipping Charge	Shipping	\$25.00	\$25.00
Sales Tax	Sales Tax (8.75%)	\$115.29	\$115.29
AED Unit Cost Total	Brand new total unit cost	\$1,717.04	\$1,551.44

Unit Price * is from price data collected for 2024-2025, unit price can vary based on time of purchase.

Renewal cost ** this can vary based on unit price, sales tax and shipping cost during the time of purchase.

The initial cost of one adult only AED unit is totaled at \$1,717.04. The renewal cost after eight to ten years is totaled at \$1,551.44. The renewal cost is less than the initial cost since there is no cost of FR-S, Flex3DWS-CPR1, and AED-Decal associated with renewal. Departments shall be aware that there is an additional cost of installation through UCR facility services, this cost is totaled at \$211.50 per unit.

A.2 Adults Only AED Unit Campus Installation Cost

One Time Cost for installation Through Facilities Services				
Product Number	Product Description	Unit Price	Quantity	Total
UCR Campus Installation	Installation of the unit through facility services requires a maintenance work order. Additionally, in the event of relocation to a new location, an extra fee will be applied, along with a new work order.	\$105.75	2 hours minimum	\$211.50

A.3 Adults Only AED Unit Total Cost with Installation

Adult Only AED Unit Total Cost				
Product Number	Product Description	Unit Price*	Quantity	Total
Adult only AED Unit Cost	Brand new AED unit cost	\$1,717.04	1	\$1,717.04
UCR Campus Installation	Installation cost of adult only AED unit	\$211.50	1	\$211.50
Total Price	Adult only AED unit + Installation cost	\$1,928.54		

A.4 Annual Agreement Cost per Adults Only AED Unit (Year 2-10)

Annual Cost per 1 Unit** as part of UCR agreement and state requirements on campus For Adult only AED's					
Product Number	Product Description	Unit Price	Quantity	When the AED Program coordinator checks the units	When the AED Department Designee checks the units

Annual Cost for one AED inspection by the AED Program Coordinator from EH&S as required by regulations.	Employee Cost = * Hourly rate: the hourly rate is \$33.65 (Employee's Hourly rate, current AED Program Coordinator)	\$33.65	A flat fee of \$168.25 is charged for a 5-hour minimum for one unit per year at on-campus locations, provided it is approved by EH&S. Additional costs will apply for multiple units, and for off-campus locations, charges will be based on drive time.	\$168.25	\$0.00
Annual AED total solution cost - system required for reporting	**Contract Term 3/1/2024 through 2/28/2025** Annual AED Total Solution Includes: Physician provided Medical Oversight, Direction, and Prescription; Written Policies and Procedures; Assigned AED Total Solution Specialist; Customized AED Total Solution Web Portal.	\$231	The fee depends on the number of units you manage. If you manage one unit, the cost is \$231 per year. If you manage five or more units, the cost is \$1155 per year.	\$231.00	\$231.00
Total	Annual Cost support for one unit			\$399.25 *	\$231.00**
*Approximate Annual Cost for 10-year support \$3,999.50					
** Approximate Annual Cost for a 10-year support \$2,310.00					

A.5 Product Usage, Replacement and Expiration Costs for Adult AED Unit

Costs associated with the usage, replacement, or expiration of equipment are factored into the budget, considering the expected 8–10-year lifespan per unit.					Example If you have 5 units
Product Number	Product Description	Unit Price	Quantity of Unit	Minimum Price of 2 Products	Price of 5 units (example)
Spare Pads replacement	Replacement cost of adult pads when expired or used at a minimum 2	\$67.15	2	\$134.30	\$671.50
Battery	Replacement of Battery when expired at a minimum 2	\$160.65	2	\$321.30	\$1,606.50
First Responder Kit	Replacement if unit is ever opened or used	\$21.60	2	\$43.20	\$216.00
Total	Over the operational lifespan of 8-10 years, including during times of low incident rates, additional costs may be incurred. These expenses will be billed as the unit undergoes changes, updates, or is deployed.			\$455.60	\$2,494.00

A.6 Initial Cost of Adults and Pediatrics Unit

Adult and Pediatric AED Unit Cost Breakdown			
Product Number	Product Description	Unit Price* (Initial Cost)	**Renewal Cost (After 8-10 Years)

M5066A C01-Onsite	Philips Heart Start Onsite AED includes 4-Year Battery, 2-Year Adult Pads Cartridge, Standard Carrying Case, 8-Year Warranty.	\$1,153.60	\$1,153.60
FRK-RD	First Responder Kit - Red. Includes items typically needed in a cardiac arrest event. The nylon, zippered pouch contains (1) pair of nitrile gloves, a pocket CPR mask, scissors, razor, and (2) towelettes.	\$21.60	\$21.60
FR-S	Cubi fully recessed small defibrillator wall cabinet with window and alarm; inside tub measures 11 1/2" L x 11 1/8"H x 7"D; outside frame measures 13 1/2"L x 13"H x 1"D. Rough wall opening size: 12 1/2"L x 12 1/8"H x 6 1/4"D.	\$143.65	\$0.00
Flex3DWS-CPR1	Transforming wall sign that can be used in three different configurations (flat, corner, triangular). Each panel measures 6 1/8" W x 9" H. Total measurements at 14 7/8" W x 9" H.	\$19.00	\$0.00
AED Decal	AED Inside' Sticker: Premium Quality - Circular - White on Red Sticker. 5H x 5W.	\$2.95	\$0.00
Quick Poster AED-0	AED/CPR Quick Reference Poster, to be posted next to AED Dimensions: 16x10x16 in	\$4.95	\$4.95
Software, Adult Pads, and Batteries (Required Initial and Annual Expense)	Annual AED Total Solution (Adult w/ Spare Adult Pads & Pediatric Pads) Includes: physician-provided medical oversight, written policies and procedures, an AED Total Solution Specialist, a customized AED Total Solution Web Portal and Mobile App, automatic no-cost replacement of pads and batteries, liability and safety consultation services, and post-event services.	\$257.00	\$257.00
Philips Heart Start FRX	Pediatric Key (good for the life of the AED)	\$97.75	\$97.75
Shipping Charge	Shipping	\$25.00	\$25.00
Sales Tax	Sales Tax (8.75%)	\$115.29	\$115.29
AED Unit Cost Total	Brand new total unit cost	\$1,840.79	\$1,675.19

Unit Price * is from price data collected for 2024-2025, unit price can vary based on time of purchase.

Renewal cost ** this can vary based on unit price and sales tax and shipping cost during the time of purchase.

The initial cost of one adults and pediatrics AED unit is priced at \$1,840.79. The renewal cost after eight to ten years is \$1,675.19. The renewal cost is less than the initial cost as there is no cost of FR-S, Flex3DWS-CPR1, and AED-Decal associated with renewal. Departments shall be aware that there is an additional cost of installation through UCR facility services, this cost is totaled at \$211.50 per unit.

A.7 Adults and Pediatrics AED Unit Campus Installation Cost

One Time Cost for installation Through Facilities Services				
Product Number	Product Description	Unit Price	Quantity	Total
UCR Campus Installation	Installation of the unit through facility services requires a maintenance work order. Additionally, in the event of relocation to a new location, an extra fee will be applied, along with a new work order.	\$105.75	2 hours minimum	\$211.50

A.8 Adults and Pediatrics AED Unit Total Cost with Installation

Adult Only AED Unit Total Cost				
Product Number	Product Description	Unit Price*	Quantity	Total
Adult and Pediatric AED Unit Cost	Brand new Adult and Pediatric AED unit cost	\$1,840.79	1	\$1,840.79
UCR Campus Installation	Installation cost Adults and Pediatrics AED unit	\$211.50	1	\$211.50
Total Price	Adults and Pediatrics AED unit + Installation cost	\$2,052.29		

A.9 Annual Agreement Cost per Adults and Pediatrics AED Unit

Annual Cost per 1 Unit** as part of UCR agreement and state requirements on campus for those with Adult/Pediatric units					
Product Number	Product Description	Unit Price	Quantity	When the AED Program coordinator checks the units	When the AED Department Designee checks the units
Annual Cost for AED checks by EH&S Employee requirements for the regulations	Employee Cost = * Hourly rate: the hourly rate is \$33.65 (Employee's Hourly rate, current AED Program Coordinator)	\$33.65	A flat fee of \$168.25 is charged for a 5-hour minimum for one unit per year at on-campus locations, provided it is approved by EH&S. Additional costs will apply for multiple units, and for off-campus locations, charges will be based on drive time.	\$168.25	\$0.00
Annual AED total solution cost - system required for reporting	**Contract Term 3/1/2024 through 2/28/2025** Annual AED Total Solution Includes Physician provided Medical Oversight, Direction, and Prescription; Written Policies and Procedures; Assigned AED Total Solution Specialist; Customized AED Total Solution Web Portal	\$257	The fee depends on the number of units you manage. If you manage one unit, the cost is \$257 per year. If you manage five or more units, the cost is \$1155 per year.	\$257.00	\$257.00
Total	Annual Cost support for one unit			\$425.25 *	\$257.00 **
* Approximate Annual Cost for 10-year support \$4,252.50					
** Approximate Annual Cost for a 10-year support \$2570.00					

A.10 Product Usage, Replacement and Expiration Costs for Adult and Pediatrics AED Unit

Costs associated with the usage and replacement of equipment are factored into the budget, considering the expected 8–10-year lifespan per unit. For those with Pediatric pads					Example If you have 5 units
Product Number	Product Description	Unit Price	Quantity of Unit	Minimum Price of 2 Products	Price of 5 units (example)
Spare Pads replacement	Replacement cost of adult pads when expired or used at a minimum 2	\$67.15	2	\$134.30	\$671.50
Spare Pads replacement	Replacement cost of pediatric pads when expired or used at a minimum 2	\$97.75	2	\$195.50	\$977.50
Battery	Replacement of Battery when expired at a minimum 2	\$160.65	2	\$321.30	\$1,606.50

Philips Heart Start FRX	Pediatric Key (good for the life of the AED)	\$97.75	1	\$97.75	\$488.75
First Responder Kit	Replacement if unit is ever opened or used	\$21.60	2	\$43.20	\$216.00
Total	Over the operational lifespan of 8-10 years, including during times of low incident rates, additional costs may be incurred. These expenses will be billed as the unit undergoes changes, updates, or is deployed.			\$792.05	\$3,960.25

Appendix B: Planning, Design & Construction (PD&C)

B.1 New Construction and Alterations Requiring AEDs

- (a) AEDs shall be placed in all newly constructed buildings, modified, renovated, or tenant improved as described by section (b) in the occupancy groups with occupant loads more than that shown in Table A. The occupant load shall be determined based on the occupant load factors in the California Building Code. Occupancy groups shall be determined based on Chapter 3 of the California Building Code.
- (b) Prior to approval of final inspection, AEDs shall be placed in all existing buildings undergoing *alteration* when any of the following apply:
- (1) The building undergoing *alteration* was constructed prior to January 1, 2017;
 - (2) The accumulated value of the *alterations* within the building within one calendar year is \$100,000 or more; or
 - (3) The *alterations* are within a public assembly occupancy use, including auditoriums and performing arts and movie theaters.
- (c) The requirements in (b) shall not apply to the following:
- (1) A general acute care hospital, acute psychiatric hospital, skilled nursing facility or special hospital licensed under Section 1250(a), (b), (c), or (f) of the California Health and Safety Code; and
 - (2) An existing AED that is located within a common area of the building described in subdivision (b) such as the main entry lobby or similar location.
- (d) AEDs shall be visibly placed and readily accessible in the event of an emergency. AEDs shall be mounted such that the top of the AED is no more than five (5) feet above floor level.

***Table A: Occupancy Groups on UCR Campus**

Occupancy Group	Occupant Load
Group A “Assembly”	300
Group E “Educational”	200
Group I “Institutional”	200
Group R “Residential” ¹	200

*Occupancy Group(s) in Table A are selected based on the relevant building types on campus.

¹ Excluding single-family and multi-family dwelling units

The following buildings on campus have an occupancy of 200 or more and do not have an AED unit on site. Evaluation is required to assess compliance with CA Health and Safety Code §19300.

The following locations in Table B: Aberdeen-Inverness, CHASS Interdisciplinary South, Winston Chung Hall, Lothian Hall, Pentland Hills Bear Cave, and Physics Building, and Spieth Hall, have been identified within the current Capital Projects Schedule. These buildings meet the occupant loads and must be evaluated for the accumulated value of alterations within the building within one calendar year.

Table B: Buildings with 200 or more Occupancy Limit

Building	Occupancy Limit
Aberdeen-Inverness	1499
Bourns Hall	1136
Boyce Hall	279
CHASS Interdisciplinary North	761
CHASS Interdisciplinary South	805
Chemical Sciences	499
Winston Chung Hall	1671
Dundee A	673
Dundee B	561
Genomics Building	473
Geology Building	327
Humanities & Social Sciences	1239
Humanities Building	610
International Village	322
Life Sciences Building	621
Lothian Hall	1122
Material Sciences Engineering	1136
North District A	1603

North District B	1020
Olmsted Hall	994
Pentland Hills Bear Cave	237
Physics Building	863
Pierce Hall	959
Psychology 1 Building	369
Science Laboratories 1 Building	240
Skye Hall	1093
Spieth Hall	538
Sproul Hall	1267
Stonehaven	556
University Lecture Hall	570
University Village Building E	270
Watkins Hall	854

Table C: Locations on UCR Campus with an AED as of 01/01/2024

Building Name	Occupant Load
Alumni & Visitors Center	165
Arts Building Fine Arts Seismic Facility	1135
Athletics and Dance	248
Batchelor Hall	414
Botanical Gardens House	9
Chancellor's Residence	4
Central Utility Plant	8
Corporate Yard D Car Shelter	0
Culver Center for the Arts	144
Boyd Deep Canyon Tevis Edu. Center	46
Environmental Health & Safety	124
Facilities Services Annex B	25

USDA Clonal Germplasm Repository	5
Heckman Center Complex PH 2	570
Ivan Hinderaker Hall	323
Highlander Union Building	2147
James San Jacinto Mtn Reserve Garage	0
Multidisciplinary Research Building 1	734
Raymond L. Orbach Science Library	1764
Parking Services Building	40
Tomas Rivera Library	1250
Police Building	55
USDA Salinity Laboratory	69
School of Medicine Education I	478
School of Medicine Education II	1164
School of Medicine Research Building	238
Student Recreation Center North	98
Student Recreation Center Pool	0
Student Recreation Center South	63
Student Health & Counseling Center	284
Student Success Center	1610
Student Support Services Building	374
USDA Modular	12

The following locations in Table D are identified as new construction(s) to the UCR campus. Their occupancy load must be evaluated based on CA Health and Safety Code §19300 standards to determine whether an AED is required in the newly constructed building.

Table D: Anticipated New Construction(s) for UCR Campus

Building Name
School of Business Building

Undergraduate Teaching & Learning Facility
Greenhouse 16-3 Rebuild
North District Phase 2
Oasis Park
PD&C Annex A

B.2 Health and Fitness Centers

AEDs are required in health studios, fitness centers and public swimming pools.

Particular public swimming pools must supply lifeguard services and AED during pool operations. Typically, any place where physical exertion is present shall have an AED because of the increased risk of cardiac arrest and other heart problems.

Effective July 1, 2007, all health clubs and health studios in California are required to have an automated external defibrillator (AED) program in place as required in the California Health and Safety code, Section 104113.

Health studios are required to supply, maintain, and train personnel on how to use an AED. For the purpose of this law, a health studio is considered a facility that allows the use of its environment and equipment to people for physical exercise, bodybuilding, reducing, figure development, fitness training, or for a similar purpose on a membership basis.

B.3 Location of AEDs

(a) AEDs shall be located in buildings to optimally achieve a three-minute response time to the person in need of emergency care using the AED.

- (1) One AED shall be placed at the main entrance; This ensures that the AED is easily accessible to anyone entering or exiting the building and is positioned in a central and commonly known location, making it more likely to be found and used quickly in an emergency situation.

B.4 AED Installation and Repair

For all newly constructed buildings that require AEDs, the AED Department Designee shall ensure monthly maintenance checks and verify that the AED is in good working condition. The AED Department Designee shall also ensure compliance with all requirements under state and federal law relating to AEDs, which may ensure that the conditions for limits on liability under state law are met. In the absence of an AED Department Designee, the Environmental Health and Safety (EH&S) AED program

coordinator will fulfill the role of the AED Department Designee. Such requirements and conditions may include, but may not be limited to the following:

- (a) Installation, maintenance, repair, testing, and readiness checks of each AED in accordance with the manufacturer's operation and maintenance guidelines, the American Heart Association, the American Red Cross, the California Code of Regulations, and all other applicable rules and regulations including but not limited to, all regulations promulgated by the federal Food and Drug Administration; and as described in section 6 AED Unit Inspection of the UCR AED program.
- (b) Upon rendering an emergency case using the AED, activate Emergency Medical Services (EMS) and the in-house emergency plan by phoning 9-1-1 system as soon as possible and report of any use of the AED. For reporting requirements reference section 7 of the UCR AED program.

B.5 AED Cubix Cabinet Dimensions and Specifications

The Cubix CB2-S and FR-S are two types of AED cabinets utilized on campus. The AED Cabinets must be installed following Americans with Disabilities Act (ADA) standards.

The height to reach the handle of an automated external defibrillator (AED) in a public gathering place shall be no more than 48 inches high. ADA guidelines specify maximum reach ranges for health equipment such as AEDs and other life safety devices. For safety equipment with an unobstructed approach, the maximum forward reach to the equipment is 48 inches above the floor. The maximum side reach for an unobstructed approach to an AED is 54 inches. For more information regarding ADA standards review and reference Appendix C.

Standard AED Wall Storage Cabinet(s)

Product Code: CB2-S

Price of one (1) CB2-S Cabinet: \$126.65



	Interior Dimensions				Exterior Dimensions			
Standard Cabinets	Height	Length	Depth		Height	Length	Depth	Weight
Small	11 1/8"	14 1/4"	6 1/2"		11 5/8"	14 3/4"	6 3/4"	7.5 lbs.
	Packaging Dimensions (1 unit)				Palletized Dimensions (60 units)			
Standard Cabinets	Height	Length	Depth	Weight	Height	Length	Depth	Weight
Small	14"	17 1/2"	10"	10 lbs.	88"	40"	48"	670 lbs.

Components included:

- Standard AED Wall Storage Cabinet
 - 0.8mm cold rolled steel
- Textured powder coating finish
- Recessed hinges
- Magnetic Door
- Keyed alarm system
- Set of two keys
- 80-120 dB local alarm
 - 9V battery
- Mounting Hardware
 - Screws (4)
 - Wall Anchors (4)
 - Washers (4)

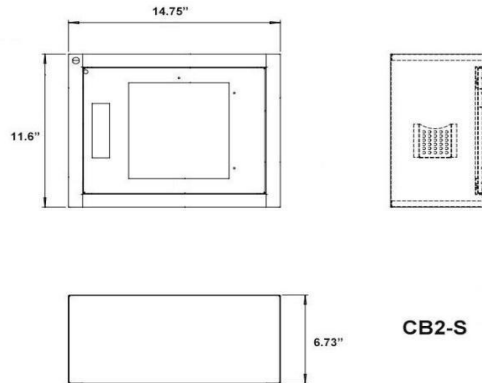



This cabinet is designed to hold Philips, Heartsine, and Defibtech AEDs.

Product Code: FR-S

Price of one (1) CB2-S Cabinet: \$143.65



	Interior/Rough Wall Dimensions				Exterior Dimensions			
Recessed Cabinets	Height	Length	Depth		Height	Length	Depth	Weight
Small	12"	12"	6 ¼"		13 ½"	13"	1"	9 lbs.
	Packaging Dimensions (1 unit)				Palletized Dimensions (40 units)			
Recessed Cabinets	Height	Length	Depth	Weight	Height	Length	Depth	Weight
Small	15"	16"	9"	11 lbs.	84"	42"	42"	620 lbs.

Components included:

- Fully Recessed AED Wall Storage Cabinet
 - 0.8mm cold rolled steel
 - Textured powder coating finish
 - Recessed hinges
 - Magnetic door
- Keyed alarm system
 - Set of two keys
 - 80-120 dB local alarm
 - 9V battery
- Mounting Hardware
 - Screws (4)
 - Wall Anchors (4)
 - Washers (4)

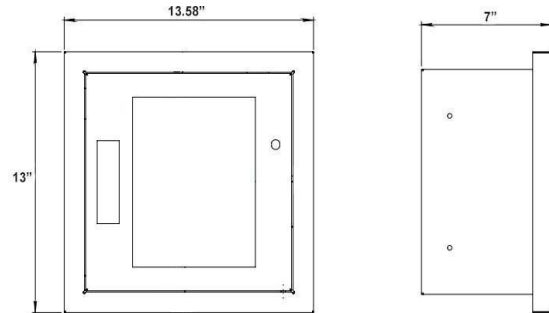

Fully Recessed-S



This cabinet is designed to hold Philips, Heartsine, and Defibtech AEDs.

B.6 AED Placement Guidelines

The AED must be located in an area accessible to all employees in an unlocked cabinet. Starting in July 2025 all AED cabinets on campus shall be alarmed in such a way that the alarm goes off when the cabinet is opened and stops when the cabinet is closed. The AED cabinets will have to utilize the 9-volt standard for the alarm system.

AED alarm systems are not required for devices within the Chancellor's home, and portable units. Portable units include but are not limited to the ones used by the UCR University of California Police Department (UCPD), athletics, and remote research sites.

The AED shall be installed at a central point relative to the building's population. Ideally, the AED is installed in a high traffic area.

- (1) One AED shall be placed at the main entrance; This ensures that the AED is easily accessible to anyone entering or exiting the building and is positioned in a central and commonly known location, making it more likely to be found and used quickly in an emergency.

The AED will have electrodes already connected and be configured in a way to be used immediately. The AED shall also have a spare set of electrodes either in the cabinet or under the lid.

The wall cabinet housing an AED must not protrude more than 4 inches from the wall into walkways, corridors, passageways, or aisles.

The AED must be clearly visible and unobstructed.

The AED must include use and reporting instructions.

To ensure compliance with applicable laws and regulations, including the Americans with Disabilities Act (ADA), the UCR campus must abide by the following requirements regarding the installation and placement of the AED unit:

B.7 AED Cabinet Installation

Per 2010 Americans with Disabilities Act (ADA) standards for Accessible Design, Section 308 unless otherwise noted (see section 2010 ADA standards for detailed description). These national standards are subject to change by authorities having jurisdiction. ADA requirements are constantly evolving through ongoing legislative and judicial actions.

B.8 AED Cabinet Height

Forward Reach

The requirements specify that the cabinet handle, and consequently the AED handle,

shall have a maximum height of 48 inches above finished floor (AFF), with a minimum height of 15 inches AFF. When reaching forward over an obstruction, the clear floor space shall extend beneath the element for distance equal to or greater than the required reach depth over the obstruction. For a high forward reach where the reach depth is 20 inches maximum, the maximum height shall be 48 inches. However, if the reach depth exceeds 20 inches, the high forward reach shall not exceed 44 inches, and the reach depth shall be limited to 25 inches.

Parallel or Side Reach

Where the side reach is unobstructed, both the cabinet handle AND the AED handle shall not exceed 48 inches in height above the finished floor or ground, with a minimum height of 15 inches. An obstruction is permissible between the clear floor or ground space and the element if the depth of the obstruction does not exceed 10 inches.

B.9 AED Cabinet Protrusion

Per [2010 ADA Standards for Accessible Design](#) requires any wall-mounted cabinet that protrudes more than 4 inches shall have the bottom corner no higher than 27 inches from the floor in a walkway.

In a circulation path (walks, hallways, ramps, stairways, landings, courtyards)

- If the mounting location is in a circulation path and the leading edge is between 27' and 80' AFF (48" in above section), it shall protrude no more than 4" maximum horizontally into the circulation path (section 204 and 307.2)
- If mounting 27 to 48 inches, the cabinet must be recessed or semi-recessed into the wall so it will not protrude more than 4 inches.
- If the cabinet has the leading edge below 27 inches, it may protrude any amount as long as it does not violate any exit corridor requirements in a room.
- If the mounting location is not in a circulation path, it may project any amount from the wall.

B.10 2010 ADA Standards

Advisory 308.1 General. The following table provides guidance on reach ranges for children according to age where building elements such as coat hooks, lockers, or operable parts are designed for use primarily by children. These dimensions apply to either forward or side reaches. Accessible elements and operable parts designed for adult use or children over age 12 can be located outside these ranges but must be within the adult reach ranges required by 308.

Children's Reach Ranges

Forward or Side Reach	Ages 3 and 4	Ages 5 through 8	Ages 9 through 12
High (maximum)	36 in (915 mm)	40 in (1015 mm)	44 in (1120 mm)
Low (minimum)	20 in (510 mm)	18 in (455 mm)	16 in (405 mm)

308.2 Forward Reach

308.2.1 Unobstructed. Where a forward reach is unobstructed, the high forward reach shall be 48 inches (1220 mm) maximum and the low forward reach shall be 15 inches (380 mm) minimum above the floor or ground.

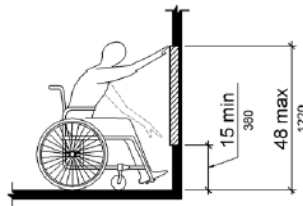

Figure 308.2.1 Unobstructed Forward Reach

308.2.2 Obstructed High Reach. Where a high front forward reach is over an obstruction, the clear floor space shall extend beneath the element for a distance not less than the required reach depth for the obstructions. The high forward reach shall be 49 inches (1220 mm) maximum where the reach depth is 20 inches (510 mm) maximum. Where the reach depth exceeds 20 inches (510 mm), the high forward reach shall be 44 inches (1220 mm) maximum and the reach depth shall be 25 inches (635 mm) maximum.

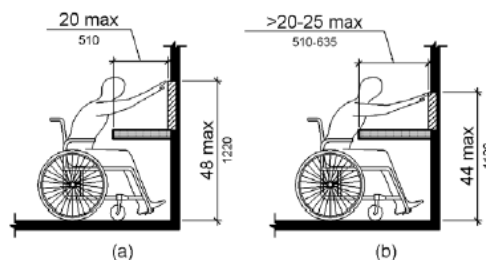

Figure 308.2.2 Obstructed High Forward Reach

308.3 Side Reach

308.3.1 Unobstructed. Where a clear floor or ground space allows a parallel approach to an element and the side reach is unobstructed, the high side reach shall be 48 inches (1220 mm) maximum and the low side reach shall be 15 inches (380 mm) minimum above the finish floor or ground.

Exceptions:

1. An obstruction shall be permitted between the clear floor or ground space and the element where the depth of the obstruction is 10 inches (255 mm) maximum.
2. Operable parts of fuel dispensers shall be permitted to be 54 inches (1370 mm) maximum measured from the surface of the vehicular way where fuel dispensers are installed on existing curbs.

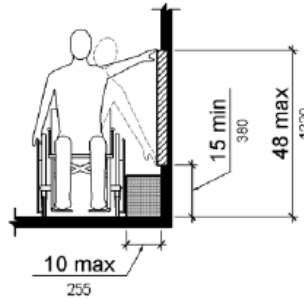
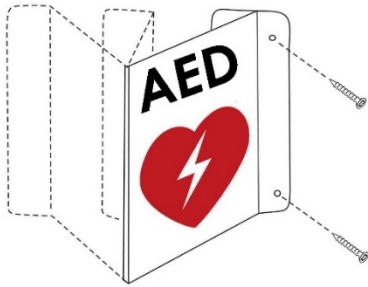

Figure 308.3.1 Unobstructed Side Reach

B.11 Signage

AED devices shall have signage at the building exterior, at the main entry door, indicating the location in the building. The sign shall include the international symbol for the AED and the text, “AED, Automatic External Defibrillator INSIDE” this part of the sign shall be 5 inches wide by 3 inches tall.



Transforming AED Wall Sign

- Change the sign shape to fit the space by choosing one of three different mounting options
- Adhesive pads included for fast and easy mounting
- Drywall anchors and mounting screws not included

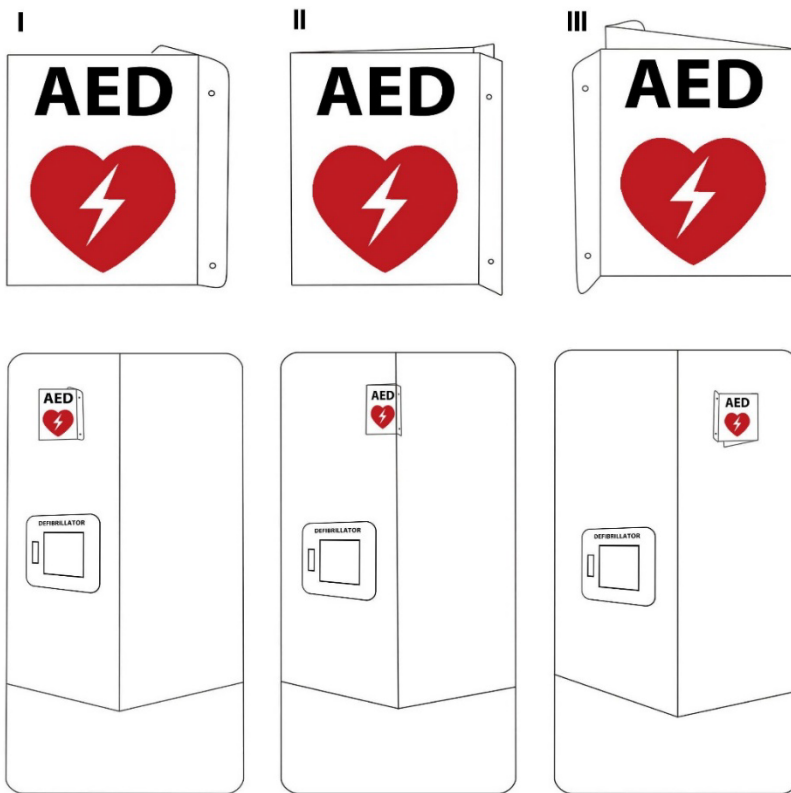

Appendix C: Facilities Services - AED Placement Guidelines

The AED must be located in an area accessible to all employees in an unlocked cabinet. Starting in July 2025 all AED cabinets on campus shall be alarmed in such a way that the alarm goes off when the cabinet is opened and stops when the cabinet is closed. The AED cabinets will have to utilize the 9-volt standard for the alarm system.

AED alarm systems are not required for devices within the Chancellor's residence, and portable units. Portable units include but are not limited to the ones used by the UCR University of California Police Department (UCPD), athletics, and remote research sites.

The AED shall be installed at a central point relative to the building's population. Ideally, the AED is installed in a high traffic area.

- (2) One AED shall be placed at the main entrance; This ensures that the AED is easily accessible to anyone entering or exiting the building and is positioned in a central and commonly known location, making it more likely to be found and used quickly in an emergency.

The AED will have electrodes already connected and be configured in a way to be used immediately. The AED shall also have a spare set of electrodes either in the cabinet or under the lid.

The wall cabinet housing an AED must not protrude more than 4 inches from the wall into walkways, corridors, passageways, or aisles.

The AED must be clearly visible and unobstructed.

The AED must include use and reporting instructions.

To ensure compliance with applicable laws and regulations, including the Americans with Disabilities Act (ADA), the UCR campus must abide by the following requirements regarding the installation and placement of the AED unit:

C.1 AED Cabinet Installation

Per 2010 Americans with Disabilities Act (ADA) standards for Accessible Design, Section 308 unless otherwise noted (see section 2010 ADA standards for detailed description). These national standards are subject to change by authorities having jurisdiction. ADA requirements are constantly evolving through ongoing legislative and judicial actions.

C.2 AED Cabinet Height

Forward Reach

The requirements specify that the cabinet handle, and consequently the AED handle, shall have a maximum height of 48 inches above finished floor (AFF), with a minimum height of 15 inches AFF. When reaching forward over an obstruction, the clear floor space shall extend beneath the element for distance equal to or greater than the required reach depth over the obstruction. For a high forward reach where the reach depth is 20 inches maximum, the maximum height shall be 48 inches. However, if the reach depth exceeds 20 inches, the high forward reach shall not exceed 44 inches, and the reach depth shall be limited to 25 inches.

Parallel or Side Reach

Where the side reach is unobstructed, both the cabinet handle AND the AED handle shall not exceed 48 inches in height above the finished floor or ground, with a minimum height of 15 inches. An obstruction is permissible between the clear floor or ground space and the element if the depth of the obstruction does not exceed 10 inches.

C.3 AED Cabinet Protrusion

Per [2010 ADA Standards for Accessible Design](#) requires any wall-mounted cabinet that protrudes more than 4 inches shall have the bottom corner no higher than 27 inches from the floor in a walkway.

In a circulation path (walks, hallways, ramps, stairways, landings, courtyards)

- If the mounting location is in a circulation path and the leading edge is between 27' and 80' AFF (48" in above section), it shall protrude no more than 4" maximum horizontally into the circulation path (section 204 and 307.2)
- If mounting 27 to 48 inches, the cabinet must be recessed or semi-recessed into the wall so it will not protrude more than 4 inches.
- If the cabinet has the leading edge below 27 inches, it may protrude any amount as long as it does not violate any exit corridor requirements in a room.
- If the mounting location is not in a circulation path, it may project any amount from the wall.

C.4 2010 ADA Standards

Advisory 308.1 General. The following table provides guidance on reach ranges for children according to age where building elements such as coat hooks, lockers, or operable parts are designed for use primarily by children. These dimensions apply to either forward or side reaches. Accessible elements and operable parts designed for adult use or children over age 12 can be located outside these ranges but must be within the adult reach ranges required by 308.

Children's Reach Ranges

Forward or Side Reach	Ages 3 and 4	Ages 5 through 8	Ages 9 through 12
High (maximum)	36 in (915 mm)	40 in (1015 mm)	44 in (1120 mm)
Low (minimum)	20 in (510 mm)	18 in (455 mm)	16 in (405 mm)

308.2 Forward Reach

308.2.1 Unobstructed. Where a forward reach is unobstructed, the high forward reach shall be 48 inches (1220 mm) maximum and the low forward reach shall be 15 inches (380 mm) minimum above the floor or ground.

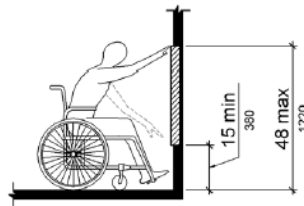

Figure 308.2.1 Unobstructed Forward Reach

308.2.2 Obstructed High Reach. Where a high front forward reach is over an obstruction, the clear floor space shall extend beneath the element for a distance not less than the required reach depth for the obstructions. The high forward reach shall be 49 inches (1220 mm) maximum where the reach depth is 20 inches (510 mm) maximum. Where the reach depth exceeds 20 inches (510 mm), the high forward reach shall be 44 inches (1120 mm) maximum and the reach depth shall be 25 inches (635 mm) maximum.

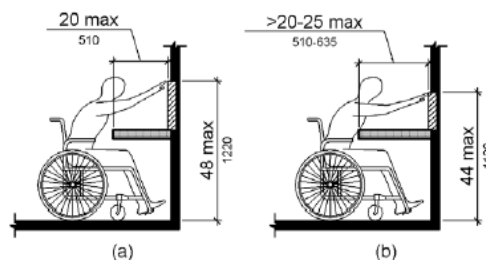

Figure 308.2.2 Obstructed High Forward Reach

308.3 Side Reach

308.3.1 Unobstructed. Where a clear floor or ground space allows a parallel approach to an element and the side reach is unobstructed, the high side reach shall be 48 inches (1220 mm) maximum and the low side reach shall be 15 inches (380 mm) minimum above the finish floor or ground.

Exceptions:

1. An obstruction shall be permitted between the clear floor or ground space and the element where the depth of the obstruction is 10 inches (255 mm) maximum.
2. Operable parts of fuel dispensers shall be permitted to be 54 inches (1370 mm) maximum measured from the surface of the vehicular way where fuel dispensers are installed on existing curbs.

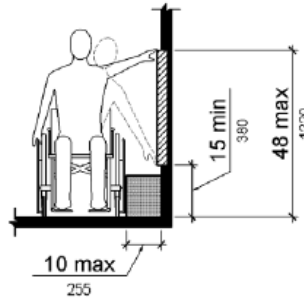

Figure 308.3.1 Unobstructed Side Reach

C.5 AED Cubix Cabinet Dimensions and Specifications

The Cubix CB2-S and FR-S are two types of AED cabinets utilized on campus. The AED Cabinets must be installed following Americans with Disabilities Act (ADA) standards.

The height to reach the handle of an automated external defibrillator (AED) in a public gathering place shall be no more than 48 inches high. ADA guidelines specify maximum reach ranges for health equipment such as AEDs and other life safety devices. For safety equipment with an unobstructed approach, the maximum forward reach to the equipment is 48 inches above the floor. The maximum side reach for an unobstructed approach to an AED is 54 inches. For more information regarding ADA standards review and reference Appendix C.

Standard AED Wall Storage Cabinet

Product Code: CB2-S

Price of one (1) CB2-S Cabinet: \$126.65



Standard Cabinets	Interior Dimensions				Exterior Dimensions			
	Height	Length	Depth		Height	Length	Depth	Weight
Small	11 1/8"	14 1/4"	6 1/2"		11 5/8"	14 3/4"	6 3/4"	7.5 lbs.
	Packaging Dimensions (1 unit)				Palletized Dimensions (60 units)			
Standard Cabinets	Height	Length	Depth	Weight	Height	Length	Depth	Weight
Small	14"	17 1/2"	10"	10 lbs.	88"	40"	48"	670 lbs.

Components included:

- Standard AED Wall Storage Cabinet
 - 0.8mm cold rolled steel
- Textured powder coating finish
- Recessed hinges
- Magnetic Door

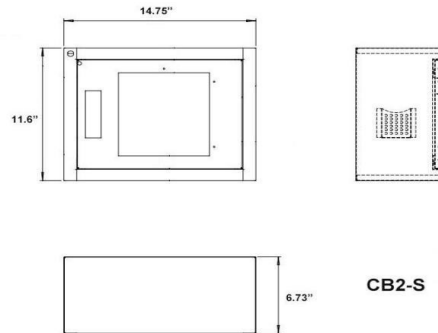

- Keyed alarm system
- Set of two keys
- 80-120 dB local alarm
 - 9V battery
- Mounting Hardware
 - Screws (4)
 - Wall Anchors (4)
 - Washers (4)



This cabinet is designed to hold Philips, Heartsine, and Defibtech AEDs.

Product Code: FR-S

Price of one (1) CB2-S Cabinet: \$143.65



	Interior/Rough Wall Dimensions			Exterior Dimensions				
Recessed Cabinets	Height	Length	Depth	Height	Length	Depth	Weight	
Small	12"	12"	6 ¼"	13 ½"	13"	1"	9 lbs.	
	Packaging Dimensions (1 unit)				Palletized Dimensions (40 units)			
Recessed Cabinets	Height	Length	Depth	Weight	Height	Length	Depth	Weight
Small	15"	16"	9"	11 lbs.	84"	42"	42"	620 lbs.

Components included:

- Fully Recessed AED Wall Storage Cabinet
 - 0.8mm cold rolled steel
 - Textured powder coating finish
 - Recessed hinges
 - Magnetic door
- Keyed alarm system
 - Set of two keys
 - 80-120 dB local alarm
 - 9V battery
- Mounting Hardware
 - Screws (4)
 - Wall Anchors (4)
 - Washers (4)

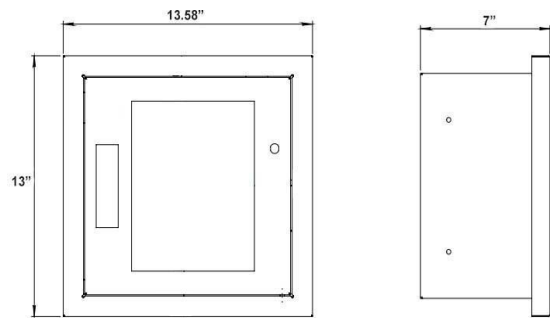

Fully Recessed-S

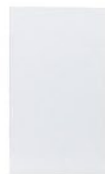

This cabinet is designed to hold Philips, Heartsine, and Defibtech AEDs.

C.6 Signage

AED devices shall have signage at the building exterior, at the main entry door, indicating the location in the building. The sign shall include the international symbol for the AED and the text, “AED, Automatic External Defibrillator INSIDE” this part of the sign shall be 5 inches wide by 3 inches tall.

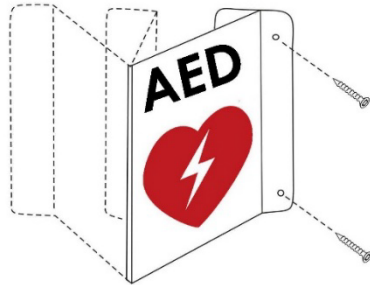

Transforming AED Wall Sign

- Change the sign shape to fit the space by choosing one of three different mounting options
- Adhesive pads included for fast and easy mounting
- Drywall anchors and mounting screws not included

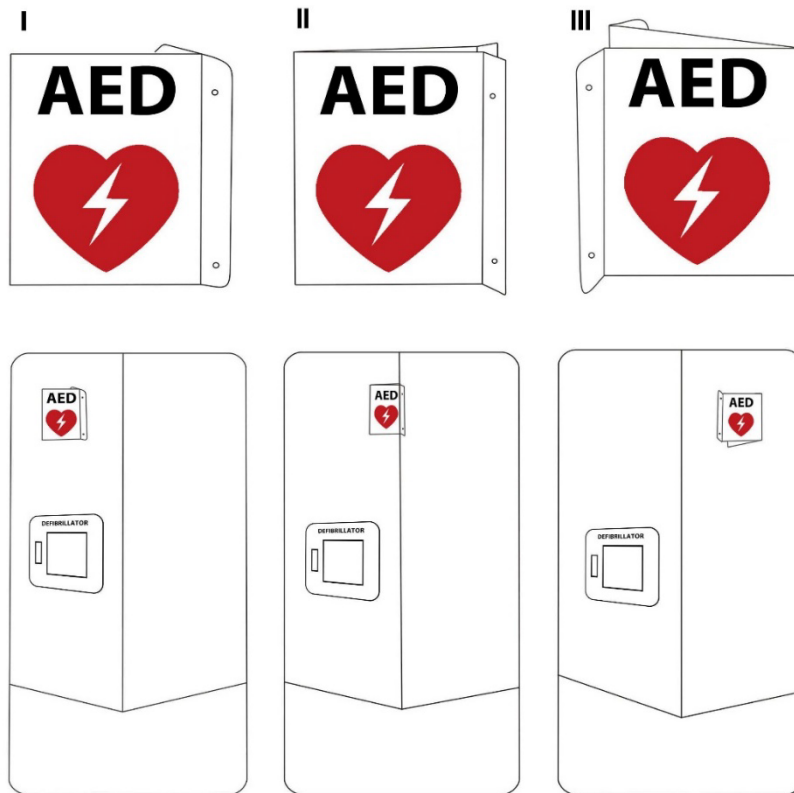

Appendix D: Automated External Department (AED) Request Form

Automated External Defibrillation (AED) Department Request Form

Date of Request:	
Department Name:	
AED Department Designee:	
AED Department Designee Phone Number:	
AED Department Designee Email Address:	
Number of AED unit(s) requested:	
Location of AED unit(s) (Building/Room):	
Department Manager:	
Checking AED unit	<input type="checkbox"/> AED Department Designee <input type="checkbox"/> EH&S AED Program Coordinator
Department COA:	

Acquiring an AED is a significant investment, **requiring 8-10 years of commitment**. Departments wishing to acquire an AED must arrange funding for the initial setup and ongoing maintenance, including replacement batteries and pads, medical oversight, and integration with the online management system. The costs for all specific work areas and vehicle units requested, unless mandated by a specific regulation, will be the **requesting department's responsibility**.

The Department or Administrative Unit agrees to the above responsibilities.

Signature: _____ Date: _____

For any inquiries or to submit this form, please contact the EH&S Occupational Health Coordinator at ehsochealth@ucr.edu.

Appendix E: UC Riverside AED Post Use Form

UC Riverside AED Post Use Form

Instructions: This form is to be completed as much as possible on-site by the AED responder or professional responders after an AED activation.

Upon the completion of this form, immediately contact the EH&S AED Program Coordinator to coordinate the pick-up of both the AED and this form within 24 hours.

ehsocchealth@ucr.edu

Your Name: _____

Department Affiliation: _____

Email: _____ Phone: _____

Were you the primary responder who used the AED? Yes No

If not, name the person who used the AED: _____

Individual's Name (optional): _____

Individual's Age: _____

Gender: _____

How the Individual Was Found:

Witness Cardiac Arrest

Found Unresponsive

Time of First Shock: ____: ____ AM PM

Date of Incident: _____

Time of Incident: ____: ____ AM PM

Location of Incident
(Address and Precise Location)

Was CPR Initiated? Yes No

Number of Shocks Delivered by AED: _____

Was the individual responsive following defibrillation with an AED? Yes No

On-Scene Outcome – Did the Individual:

Regain a heartbeat? Yes No

Resume breathing? Yes No

Regain consciousness? Yes No

Individual’s Outcome (if known):

Discharged Alive____ DOA at ER____ Died in ER____ Died within 24 hrs.____ Died after 24 hrs.____

Other:

Responding EMS Service:

Estimated Response Time: ____: ____ AM PM

Receiving Hospital (if known):

Additional Responder Names:

Additional Comments
